

# Small-Scale Cold Rooms for Perishable Commodities

JAMES F. THOMPSON, AGRICULTURAL ENGINEER

MARK SPINOGLIO

DEPARTMENT OF BIOLOGICAL AND AGRICULTURAL ENGINEERING  
UNIVERSITY OF CALIFORNIA, DAVIS

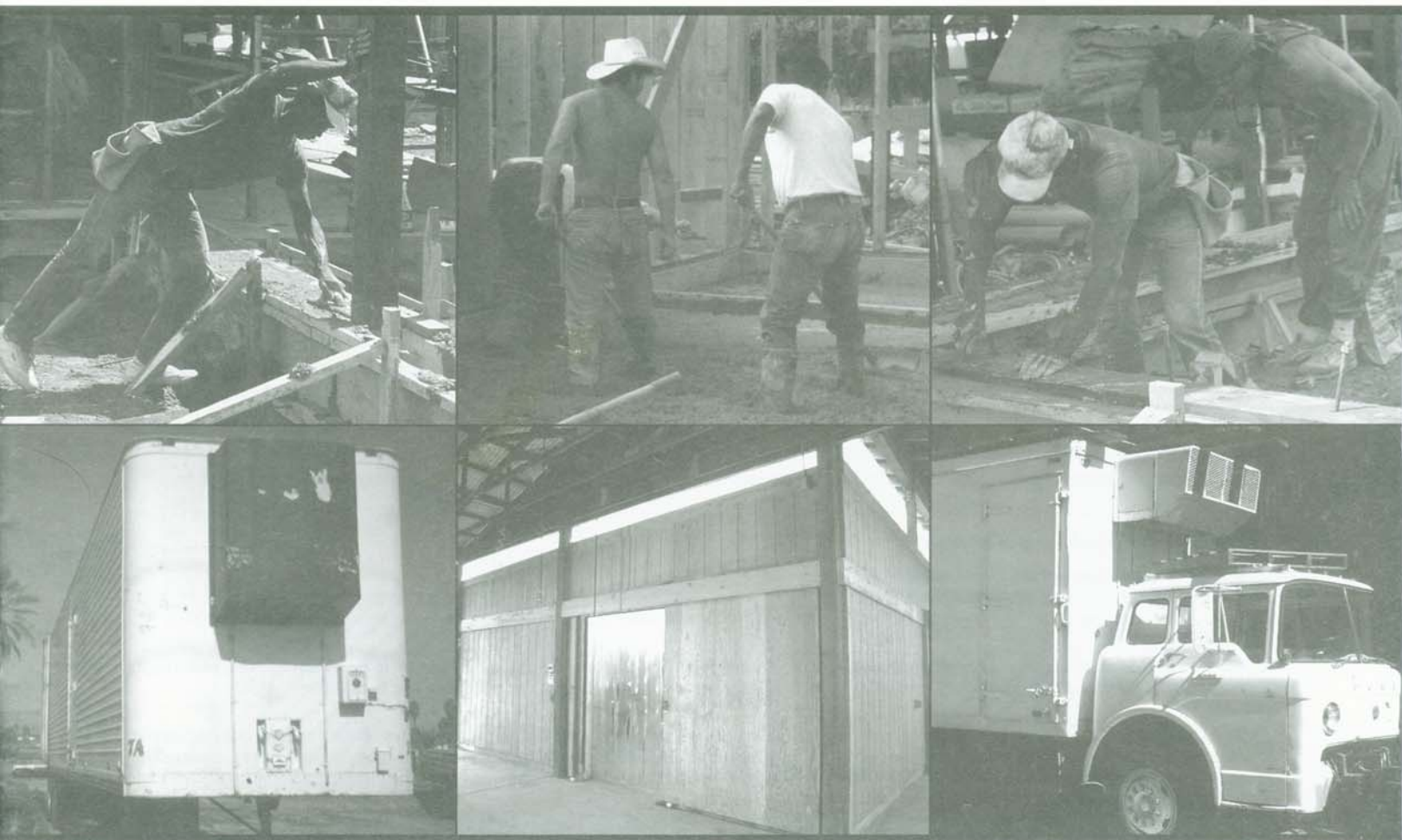

University of California • Division of Agriculture and Natural Resources

Publication 21449

For information about ordering this publication, contact

University of California  
Communication Services—Publications  
Division of Agriculture and Natural Resources  
6701 San Pablo Avenue, 2nd Floor  
Oakland, California 94608-1239

Telephone (510) 642-2431  
within California (800) 994-8849  
FAX (510) 643-5470  
e-mail inquiries to [anrpubs@ucdavis.edu](mailto:anrpubs@ucdavis.edu)

**Publication 21449**

Printed in the United States of America.

©1996 by the Regents of the University of California  
Division of Agriculture and Natural Resources

All rights reserved.

No part of this publication may be reproduced, stored in a retrieval system, or transmitted, in any form or by any means, electronic, mechanical, photocopying, recording, or otherwise, without the written permission of the publisher and the authors.

The University of California, in accordance with applicable Federal and State law and University policy, does not discriminate on the basis of race, color, national origin, religion, sex, disability, age, medical condition (cancer-related), ancestry, marital status, citizenship, sexual orientation, or status as a Vietnam-era veteran or special disabled veteran. The University also prohibits sexual harassment. This publication is available in alternative media on request.

Inquiries regarding the University's nondiscrimination policies may be directed to the Affirmative Action Director, University of California, Agriculture and Natural Resources, 300 Lakeside Drive, 6th Floor, Oakland, CA 94612-3560, (510) 987-0096.

Im rev. 9/96-TC/TB



Printed on recycled paper

---

# Small-Scale Cold Rooms for Perishable Commodities

Temperature management is the key to maintaining the freshness of fruits, vegetables, and cut flowers after harvest. By investing in a cold room, small-scale farmers, packers, or merchants can significantly slow the quality loss of their produce. Here we describe the choices producers have in buying or building cold-storage facilities.

## PLANNING

### Location

The cold room should be conveniently located. If its purpose is to hold produce after harvest and before delivery to a wholesaler or retailer, it should be accessible from the field because time lost between harvest and initial cooling can seriously reduce quality. For many commodities, 1 hour at a field temperature of 90°F will reduce quality as much as several days in storage under proper temperature conditions.

If the cold room is to be used in conjunction with a retail outlet, locate it so produce can be conveniently moved from cold storage as displayed products are sold and easily returned at the end of the day. In addition, the cold room site should have good drainage and access to utilities and permit expansion as the business grows.

### Size of a cold room

Cold room size is based on the typical volume of produce (measured in cubic feet) handled during a peak harvest or a peak sales day. To determine the required floor area (in square feet), divide the produce volume by the height (in feet) to which produce can be stacked. Shelves can be used to increase the effective stacking height of some products. Within the storage area, plan for a 6-inch distance between the product and the interior walls to allow for good air circulation. Area is also needed for aisles (fig. 1). Aisle width, which is based on cold room size, should be at least 3 feet for a small walk-in room. A larger cold room that accommodates pallets should have aisles at least 6 feet wide to allow the use of pallet jacks. Wider aisles may be needed for forklifts.

To guarantee good air flow, the cold room ceiling should be at least 12 to 18 inches higher than the produce. If the cold room is used for initial cooling and there is no forced-air cooling, allow extra room so that the product can be spread out for exposure to cold air. After cooling, the produce can be stacked for storage.

### Temperature

Each product has an optimum storage temperature. Based on the product or products being stored at time

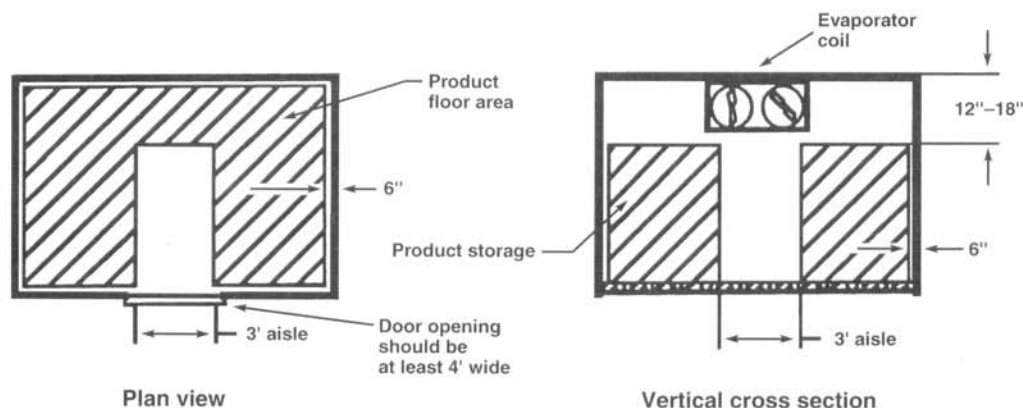

**Table 1. Compatible fresh fruits and vegetables during seven-day storage**

Group 1 32–36°F, 0–2°C & 90–98% relative humidity (rh)			Group 2 45–50°F, 7–10°C & 85–95% rh	Group 3 55–65°F, 16–18°C & 85–95% rh	
<b>Vegetables</b>					
alfalfa sprouts	Chinese cabbage	mushroom	basil	bitter melon	
amaranth	Chinese turnip	mustard greens*	beans: snap, green, wax	boniato	
anise	collard*	parsley*	cactus leaves (nopales)	cassava	
artichoke	corn: sweet, baby	parsnip	calabaza	dry onion	
arugula*	cut vegetables	radicchio	chayote*	ginger	
asparagus*	daikon*	radish	cowpea (Southern pea)	jicama	
bean sprouts	endive*-chicory	rhubarb	cucumber*	potato	
beans: fava, lima	escarole*	rutabaga	eggplant*	pumpkin	
beet	fennel	salsify	kiwano (horned melon)	squash: winter (hard rind)*	
Belgian endive*	garlic	scorzonera	long bean	sweet potato*	
bok choy	green onion*	shallot	malanga	taro (dasheen)	
broccoli*	herbs* (not basil)	snow pea*	okra*	tomato: ripe, partially ripe & mature green	
broccoli* flower*	horseradish	spinach*	pepper: bell, chili	yam*	
brussels sprouts*	Jerusalem artichoke	sweet pea*	squash: summer,(soft rind)*		
cabbage*	kale	Swiss chard	tomatillo		
carrot*	kailan	turnip	winged bean		
cauliflower*	kohlrabi	turnip greens*			
celeriac	leek*	water chestnut			
celery*	lettuce*	watercress*			
chard*	mint				
<b>Fruits and Melons</b>					
apple	currant	loquat	avocado, unripe	limequat	atemoya
apricot	cut fruits	nectarine	babaco	mandarin	mamey
avocado, ripe	date	peach	cactus pear, tuna	olive	mango
Barbados cherry	dewberry	pear: Asian, European	calamondin	orange	breadfruit
blackberry	elderberry	persimmon*	carambola	passion fruit	canistel
blueberry	fig	plum	cranberry	pepino	casaba melon
boysenberry	gooseberry	plumcot	custard apple	pineapple	cherimoya
caimito	grape	pomegranate	durian	pomelo	crenshaw melon
cantaloupe	kiwifruit*	prune	feijoa	sugar apple	honeydew melon
cashew apple	litchi	quince	granadilla	tamarillo	jaboticaba
cherry	loganberry	raspberry	grapefruit*	tamarind	jackfruit
coconut	longan	strawberry	guava	tangelo	
			Juan Canary melon	tangerine	
			kumquat	ugli fruit	
			lemon*	watermelon*	
			lime*		

NOTE: Ethylene level should be kept below 1 ppm in storage area.

\*Sensitive to ethylene damage.

of storage, an optimum operating temperature can be determined. Table 1 lists recommended temperatures for short-term storage of many types of perishable products. If products from different groups are handled, then separate cold rooms are required. Long-term storage temperatures sometimes differ slightly from those listed in table 1, especially for products in groups 2 and 3. A reference like USDA Handbook 66, *Commercial Storage of Fruits, Vegetables, Cut Flowers and Nursery Stock* provides specific temperature recommendations.

### THE CHOICES

Cold rooms can be purchased new or used as prefabricated units; can be owner-built; or can be made from used refrigerated transportation equipment, such as rail cars, marine containers, or highway

vans. The choice should be based on affordability, availability of equipment in the area, and the amount of time available for building a structure or modifying transport equipment.

Table 2 shows cost estimates for various cold room options. Evaluated on a per-square-foot basis, a new commercially installed cold room is one of the most expensive choices. A unit with about as much floor area as a typical refrigerated transport vehicle costs \$45 per square foot, but the cost of smaller rooms can be much greater. For example, one manufacturer quoted a cost of about \$160 per square foot for a small (6 × 8-foot) room compared with the \$45 per-square-foot cost of a 20 × 20-foot room. Using refrigerated transport vehicles is cost competitive with commercially installed new units and may be slightly cheaper in some cases. Building the cold room yourself or buying a used prefabricated cold

**Table 2. Cost comparison of small-scale cold rooms**

Type of cold room	Cost (dollars per square foot)		
	Equipment & materials	Modification & transport to site	Total
New prefabricated*	—	—	45
Used prefabricated†	10–30	0	10–30
Rail car‡	6	22–27	28–33
Highway van§	33–45	0	33–45
Marine container//	30–33	5–10	35–43
Owner-built#	10–20	0	10–20

\*Prefabricated panels with metal interior and exterior facing attached to foam-board insulation. Building assembled by a commercial contractor, 400 square feet of floor area, and 2-hp refrigeration system installed (add 5% if installed outside).

†Owner installed.

‡Diesel/electric refrigeration system. Floor dimensions are 9 × 45 feet.

§Diesel powered. Cost to convert to electrically powered refrigeration is \$10 to \$20 per square foot. If wheels are left attached, a truck-high dock or ramp may need to be installed at extra expense.

//Electrically powered; no wheel, axles, or suspension system are attached.

#Wood-frame construction, similar to plan in figure 6. Installed by owner and includes a contractor-installed, used refrigeration system.

room are the least expensive options, but the cost is based only on the cost of materials and does not include the cost of planning and construction time.

### Prefabricated cold rooms

Prefabricated cold rooms are most often bought used from restaurants or stores that are going out of business or are remodeling. A few companies specialize in selling used equipment. The cold room walls are usually assembled in sections, which makes moving and reassembly fairly simple. The sections or panels consist of foam insulation covered on both sides with metal or plastic. The panels use special attachment systems to allow quick installation. Most prefabricated coolers are not weather-tight and must be assembled within an existing structure.

### Rail cars

Railroad companies occasionally offer refrigerated rail cars to the public for purchase. These cars are very sturdy and were originally well insulated. Refrigeration is run by a 440-V, three-phase electric motor that is powered, in turn, by a diesel engine generator. The generator set can be salvaged and the refrigeration connected to the electric utility (provided there is 440-V, three-phase power available). Cars have 9-foot, 4-inch-high ceilings, which limit the height to which produce can be stacked. Doors on a rail car are located in the center of the side walls, allowing easier access to the product than the doors of marine containers and highway vans, which

are located at the end of the unit. Because rail cars are usually sold without rail trucks (wheels), the biggest problem that most purchasers have is getting the car from the railroad to the farm site. It is possible, however, to devise a method for putting dollies in place of the rail car trucks and hauling the car over the road. Others have rented crane services and a highway trailer to transport the rail car over the highway.

### Highway vans

Used refrigerated highway vans have a unique advantage as cold rooms (fig. 2): the room is portable if the wheels are left on. If the production



Figure 2. Refrigerated highway van used as a cold room.



site changes, the cold room can be moved to the new location. Because of the wheels, however, the floor of a highway van is usually about 4 feet off the ground, which may make moving products in and out of the van more difficult.

The refrigeration system is powered directly with a diesel engine, a benefit if utility electricity is not available at the cold room site, although engine-driven units are noisy and may disturb neighbors. In some areas, it may be less expensive to operate the refrigeration if it is converted to operate with an electric motor, but converting is expensive, and the cost must be added to the project.

Highway vans and other refrigerated transit vehicles are limited to 3-foot aisles because their inside width is 7.5 to 8 feet. To remove product loaded in the front of the unit, an aisle is needed along the full length of the vehicle (fig. 3). Unfortunately, the aisle occupies about 40% of the total floor area in the trailer, causing the cost per usable floor area to be nearly double the amount shown in table 2.

Because highway vans are built light to maximize the weight they can carry, used vans are often in poor condition. Frequently the already-limited insulation has deteriorated, door seals are poor, and other damage has occurred that permits a lot of air leakage. Vans in poor condition are less expensive to purchase but do not provide adequate cold storage and are more costly to operate in the long run. Carefully inspect a used trailer before buying it (for details to consider, see fig. 4).

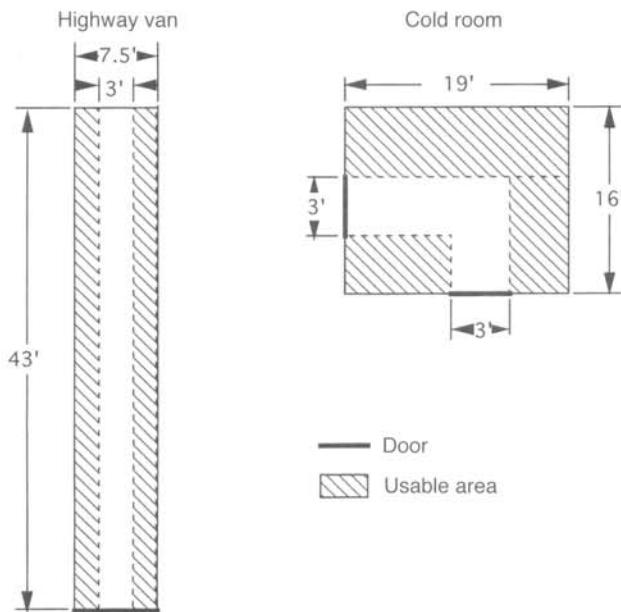

Figure 3. Usable floor area for refrigerated transit vehicles and a commercial or owner-built cold room, each with a 300-square-foot maximum floor area.

## Marine containers

Marine containers are available in 20-, 24-, and 40-foot lengths. Their built-in refrigeration unit is powered with 220-V or 440-V, three-phase electricity, and they can be plugged directly into utility power. They are usually well built, and have deep T-beam floors and fan capacity that offers good air circulation. In fact, the air circulation can provide adequate room cooling.

A disadvantage of all transport vehicles is that their refrigeration system is not designed to produce high relative humidity, and low humidity causes products to dry out, resulting in weight loss and poor quality. This is particularly a problem if the cold room is going to be used for long-term storage. One way to reduce drying is to keep the floor and walls wet, but this increases corrosion, reduces equipment life, and increases the need for defrosting. Product can also be packed in plastic bags or box liners to slow moisture loss.

## OWNER-BUILT COLD ROOMS

In many cases, an owner-built cold room (fig. 5) is the least expensive option. Figure 6 provides all the basic details for constructing a small cold room. The framing is 2 × 6-inch structural lumber, 24 inches on center, with exterior-grade plywood covering the inside and outside. The sole plate (mud sill) and, if possible, the wall guard should be pressure treated to resist decay caused by moisture. The 2 × 6-inch framing allows the use of R-19 fiberglass insulation, which is recommended over the R-11 fiberglass insulation used with 2 × 4-inch framed walls (higher R-values indicate greater insulation properties). Other types of insulation with higher R-values per inch than fiberglass (such as extruded polystyrene

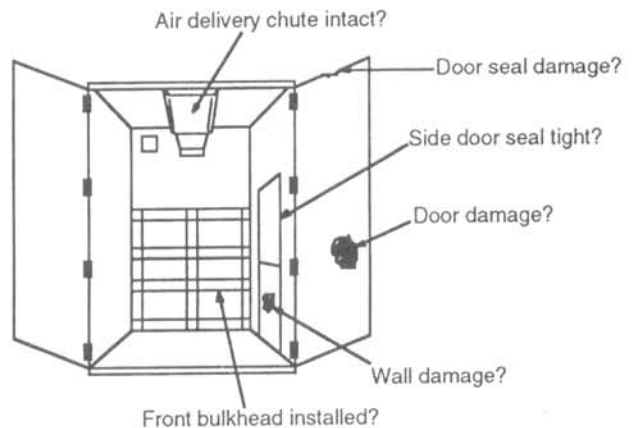

Figure 4. Factors to consider when inspecting a used trailer for purchase as a cold room.

or urethane sheets) can be used, but they usually cost more than fiberglass for the same R-value. Insulation levels greater than R-19 can be achieved by using 2 × 8-inch framing or covering the framing with board insulation.

A vapor barrier must be installed on the warm side of the insulation, usually the outside for a cold room. Without a vapor barrier, water will condense in the insulation, which reduces its effectiveness and may allow dry rot in wood studs and joists. A 4- to 6-mil thick polyethylene sheet is a good vapor barrier. The vapor barrier should be installed after the wall and ceiling are framed and prior to installing the exterior plywood covering. Joints should be overlapped at least 12 inches and taped, and the vapor barrier should be stapled to the studs and joists to keep it in place during construction. To create a seal at the base of the wall, silicon sealer should be applied between the vapor barrier and the sole plate metal shield.

A foundation is not necessary for a cold room built in an existing structure or on an existing concrete pad. When a foundation is built, heat gain across the foundation should be considered. Rigid insulation can be placed under the concrete floor or placed vertically on the outside of the perimeter foot-



Figure 5. An owner-built cold-storage unit.

ing. The concrete and board insulation of the floor allows moisture through in the same manner as the walls, and, therefore, a vapor barrier such as 6-mil polyethylene sheeting is needed between the soil and the insulation or concrete slab. To prevent soil moisture from freezing, cold storage for frozen products requires special precautions including high levels of floor insulation and a system for heating the soil.

An existing noninsulated, framed structure can be converted into a cold room with a few modifications. A polyethylene vapor barrier must be applied to the inside of the framing or inside sheathing to reduce vapor penetration. A 2-, 3-, or 4-inch board insulation is installed against the inside of the vapor barrier (thicker insulation has a higher insulation value). Covering the insulation with exterior-grade plywood protects it. The board insulation should not be installed on a structure that has existing insulation because condensation problems may occur in the existing insulation. Seals need to be added to the doors to decrease air infiltration. Most importantly, all door locks must be removed to prevent accidentally locking a person in the cold room.

Figure 6 shows two types of doors that can be used. Small cold rooms permit a great amount of warm air to enter when a door is opened, thereby increasing energy use and, more importantly, allowing the temperature to rise in the room. Air infiltration increases with the size of the door but can be significantly reduced by installing plastic or canvas flap doors just inside the wooden door. The door width may vary depending on the producer's needs. If pallets are used, then the door width must be at least 54 inches.

### Refrigeration systems

A  $\frac{3}{4}$  to 1 horsepower refrigeration system is generally adequate for a 100-square-foot cold room. Figure 7 provides estimated refrigeration capacity for other cold room sizes. Most cold room sites in California fit within the two climates shown. Warm areas can use the data for the Central Valley, and cooler areas can use the Coastal data. After determining the optimum floor area for the cold room, use the product's optimum storage temperature from table 1 to determine the refrigeration capacity needed for the cold room. The tons of refrigeration is approximate but allows estimation of the equipment cost. Figure 8 is an example refrigeration calculation based on figure 7. More capacity would be needed for rapid cooling methods like forced-air cooling.

Higher humidity can be maintained in a cold room if the evaporator coil is oversized. This allows the coil to operate at a relatively high temperature, thereby reducing the amount of condensation on

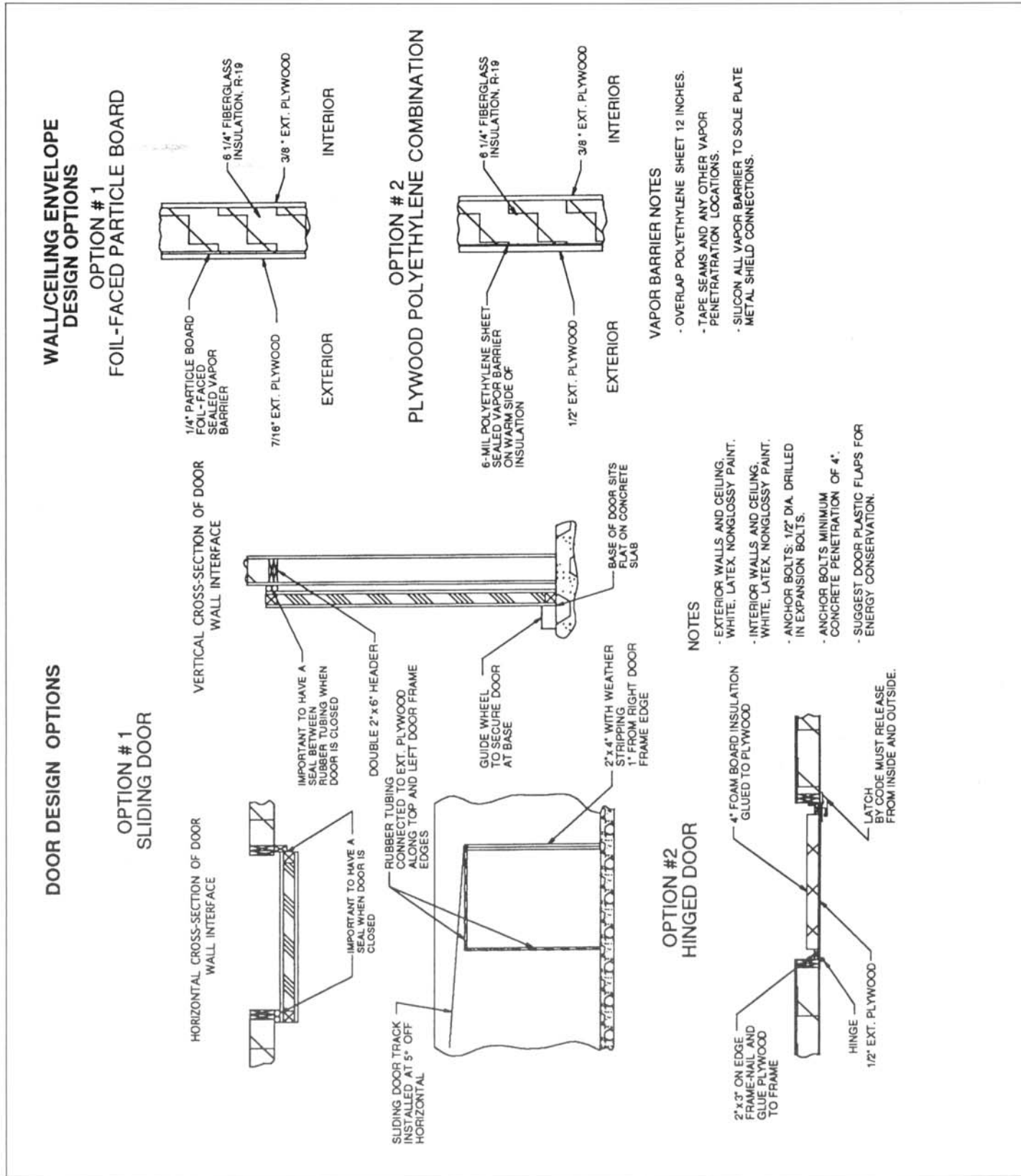
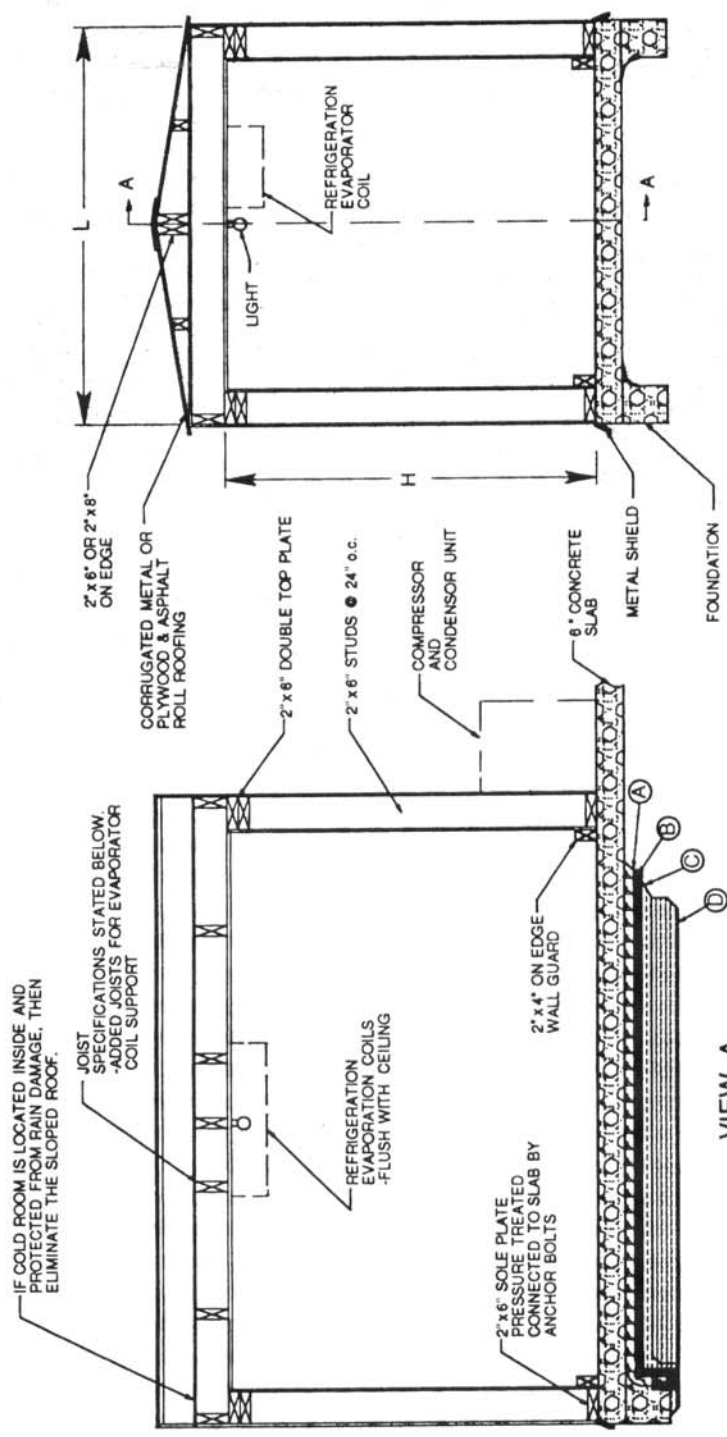
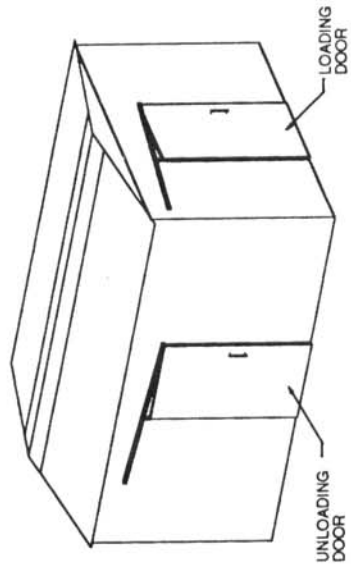

Figure 6. Plan for an owner-built cold room.





VIEW A



JOIST SPECIFICATIONS

- JOIST
- L < 10'
  - 10' < L < 14'
  - 14' < L < 16'
- H = 10' MINIMUM
- 2" x 6" @ 24" o.c.
  - 2" x 8" @ 24" o.c.
  - 2" x 8" @ 16" o.c.

- LATERAL BRACING AT MIDPOINT OF JOIST.
- STRUCTURAL LUMBER
- SPECIFICATIONS MAY VARY WITH LOCATION.
- SNOW LOADING IS NOT CONSIDERED.
- FOR COLD ROOM WIDTHS GREATER THAN 16', CONSULT AN ENGINEER.
- FOR EVAPORATOR COIL SUPPORT CHANGES TO JOIST SIZE OR SPACING MAY BE NECESSARY.

CONCRETE SLAB DETAILS

- A - OPTIONAL
- 2" FOAM BOARD INSULATION
  - 25 psi COMPRESSION STRENGTH
- B - 6-MIL POLYETHYLENE VAPOR BARRIER
- C - 2" SAND LAYER
- D - 4" GRAVEL LAYER
- FOUNDATION IS NECESSARY FOR LARGER UNITS.

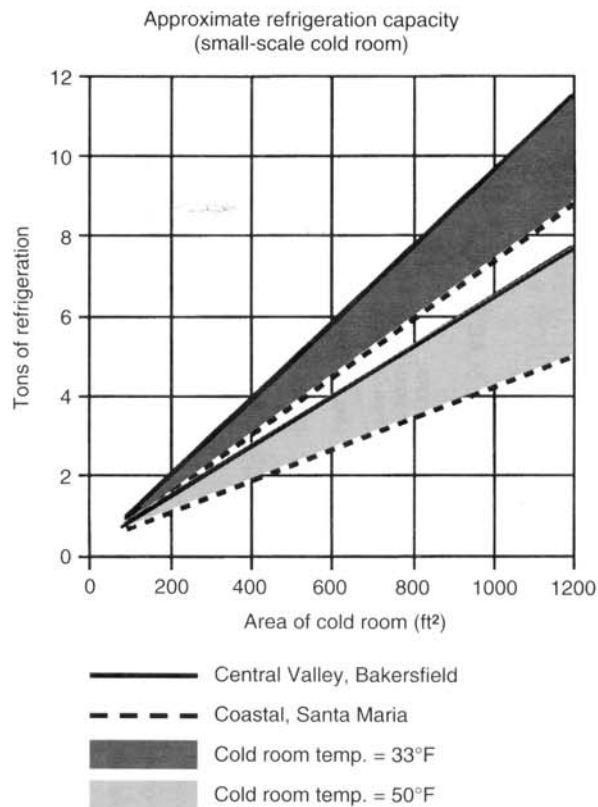

Figure 7. Approximate refrigeration capacity for small-scale cold rooms.

#### Required Information

The cold room is located in Yolo County (in the Central Valley of California). The room is used to store pears at 33°F in boxes stacked seven high. The box dimensions are 11 inches high, 11.4 inches wide, and 18.5 inches long. The turnover rate is estimated at 581 new boxes added every 24 hours and an equal number removed each day. Boxes are held in the room for 2 days. Therefore, the cold room holds a maximum of 1,162 boxes. The answers have been rounded off to three significant digits.

#### Cold Room Size

The usable area is

$$(1,162 \text{ boxes}) \times (11.4 \times 18.5 \text{ in}) = 35,000 \text{ in}^2 = 243 \text{ ft}^2,$$

(7 boxes high)

assuming that 80% of the floor area is usable for box storage.

$$\text{Total cold room area} = \frac{243 \text{ ft}^2}{0.8} = 304 \text{ ft}^2.$$

This is a 16 × 19-foot cold room with a loading and an unloading door as shown in figure 3.

#### Refrigeration Capacity

A cold room with a 300-square-foot floor area held at 33°F in the Central Valley requires about 3 tons of refrigeration according to figure 7.

Figure 8. Example calculation of refrigeration requirement for a small cold room.

the coil and increasing humidity in the room. The refrigeration control system must be designed to keep the evaporator at the highest possible temperature. Common control systems are not designed to operate an evaporator for high humidity. Ask your refrigeration contractor about which controls are needed to operate your evaporator coils to obtain high humidity. High evaporator temperatures also reduce frost buildup on the coils, which should have a warm-water or electric defrost system. A warm-water defrost system requires a system for draining defrost water outside the cold room. Wood construction will not last long if wood is wetted frequently, and insulation loses its resistance to heat flow if it is wet.

Refrigeration systems must be controlled by an accurate thermostat placed away from the door. Check the thermostat's calibration by placing a remote reading thermometer in the cold room with the display installed in a convenient location on the outside of the room. Calibrate the thermometer with an ice bath (a stirred mixture of ice and water has a temperature of about 32°F), and check the thermometer regularly to see that the thermostat is maintaining the proper temperature.

If the cold room is going to be kept above 50°F, it may be possible to use a room air conditioner instead of a packaged refrigeration unit. Air conditioners will build up ice on the cold evaporator coil if they are operated at temperatures below 50°F. They also do not have the capacity for initial product cooling. An air conditioner costs about half as much as a refrigeration unit of equivalent size.

#### Evaporative coolers

Evaporative cooling can also be used as a substitute for mechanical refrigeration. Figure 9 shows the important elements of an evaporative cooler. (See figure 10 for an example calculation of fan size, pad area, water reservoir volume, and vent area for evaporatively cooled storage.) It will produce air temperatures equal to 2° to 3°F above the wet bulb temperature of the outside air. In the summer in California, air can be dependably cooled to 65° to 75°F. Coolers can be purchased as packaged units or built from parts available at most hardware stores.

To achieve the lowest possible temperatures, an evaporative cooler should have 1 square foot of pad area for each 150 cubic feet per minute (cfm) of air moved by the fan. Fan capacity is related to the volume of the cold room. The fan should have the capacity to exchange the air volume in the room completely once every 2 minutes. For example, a 2,000-cubic-foot room needs a fan with a 1,000-cfm capacity. The fan should be rated at this capacity

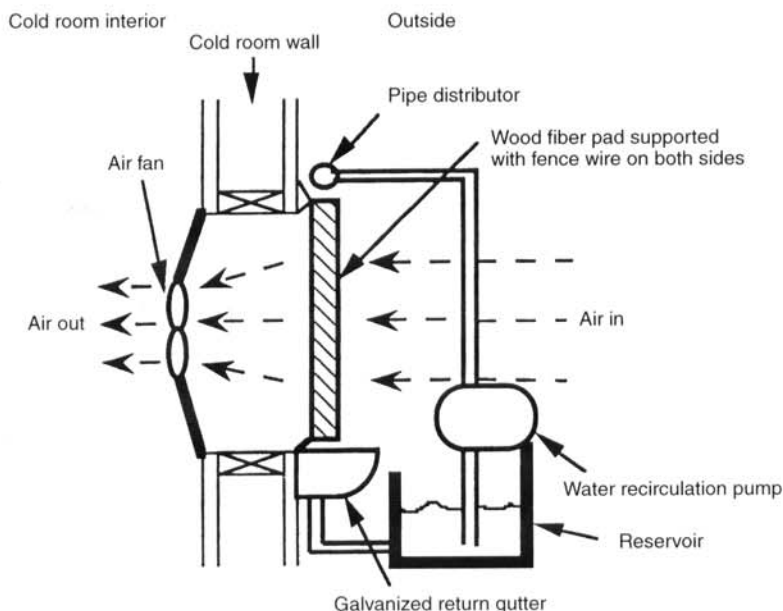

Figure 9. Components of an evaporative cooler.

#### Required Information

The cold room is located in Yolo County, California (designed for a maximum temperature of 100°F and relative humidity of 30%). The desired room temperature is 75°F.

#### 1. Fan Capacity

Cold room volume =  $(300 \text{ ft}^2) \times (10 \text{ ft}) = 3,000 \text{ ft}^3$   
 Fan capacity =  $(3,000 \text{ ft}^3) \times (0.5 \text{ air changes per minute}) = 1,500 \text{ cfm}$

#### 2. Pad Area

Pad area =  $(1,500 \text{ cfm}) \times (1 \text{ ft}^2/150 \text{ cfm}) = 10 \text{ ft}^2$

#### 3. Reservoir Volume

Assume pad is 2 feet high and 5 feet long.  
 Reservoir volume =  $(5 \text{ ft}) \times (1.3 \text{ gallons/ft}) = 6.5 \text{ gallons}$

#### 4. Water Pump Capacity

Water pump capacity =  $(5 \text{ ft}) \times (0.3 \text{ gallons per minute/ft}) = 1.5 \text{ gpm}$

#### 5. Vent Area

Total vent area =  $(1,500 \text{ cfm}) \times (1 \text{ ft}^2/500 \text{ cfm}) = 3 \text{ ft}^2$

Figure 10. Example calculation of fan size, pad area, water reservoir, and vent area for evaporatively cooled storage.

operating against a 1/8-inch water-column, static pressure. The water pump for the cooler needs a capacity of 1/3 gallon per minute per foot of pad length, and the reservoir should have a holding capacity equal to 1.3 gallons per foot of pad length. Reservoirs are often set up with a float valve to main-

tain a constant water amount in them. A small amount of water should be continuously drained from the reservoir to prevent salt buildup on the pads.

Cold air from evaporative coolers should be introduced near the ceiling and flow through the room and exit through exhaust vents. Air that has been evaporatively cooled once cannot be recirculated and cooled again. The vents should be positioned near the floor and around the perimeter of the room. This placement will cause the cooled air to flow to all parts of the room. Total vent area in square feet should equal the fan capacity in cubic feet per minute divided by 500 cfm per square foot.

#### ADDITIONAL INFORMATION

A companion video to this leaflet provides more information about building a small-scale cold-storage room. The video, "Cold Storage for Small Farms," describes the cost and usefulness of different types of small-scale cold storage and gives details regarding planning and construction of a storage room. Video V94-J is 13 minutes long. It can be ordered from DANR Communication Services, University Services Building, Room 131, 1441 Research Park Drive, University of California, Davis, California 95616; E-mail: [skwillard@ucdavis.edu](mailto:skwillard@ucdavis.edu); phone: 916-757-8980; fax: 916-757-8991. Call or write for information about international orders.